

TOP VIEW

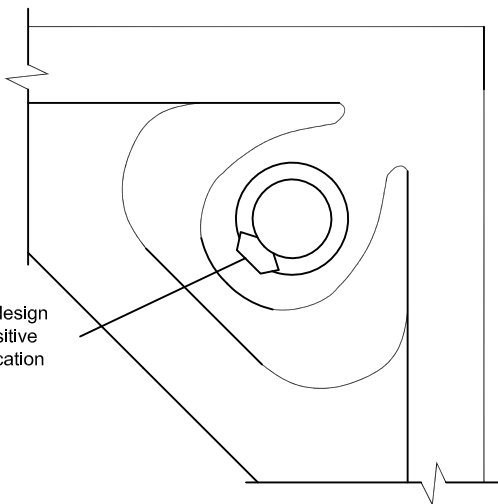

CORNER DETAIL

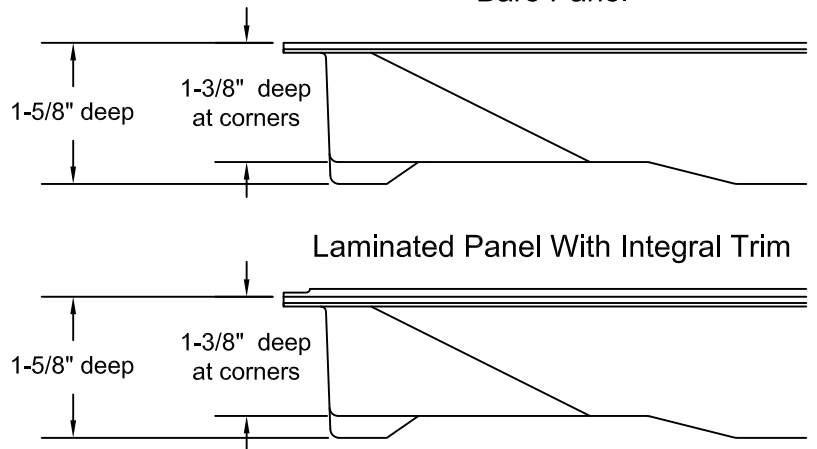

## SPECIFICATIONS

### General information

- Panel weight : 8.0 lbs./ft<sup>2</sup> bare.
- All steel welded construction filled internally with a cementitious core material.
- Protected from corrosion by an epoxy paint finish.
- Class A flame spread rating.
- Non-combustible material.

## UNDERSTRUCTURE OPTIONS

- Freestanding
- Posilock
- 2' Bolted Stringer
- 4' Bolted Stringer

## COVERING OPTIONS

Tile factory laminated with integral trim edge

- 1/8" HPL \_\_\_\_\_ (Color) \_\_\_\_\_
- 1/16" HPL \_\_\_\_\_ (Color) \_\_\_\_\_
- 1/8" Conductive HPL \_\_\_\_\_ (Color) \_\_\_\_\_
- 1/16" Conductive HPL \_\_\_\_\_ (Color) \_\_\_\_\_

For additional laminate options contact Inside Sales

Bare Painted Panel Options

- Bare Painted Finish to accept carpet tile application
- Bare Painted Finish to accept PosiTile application

### Bare Panel

### Laminated Panel With Integral Trim

System Performance Criteria (Tested on Actual Understructure)*								
System Type	Understructure	SYSTEM WEIGHT	STATIC LOADS			ROLLING LOADS		IMPACT LOADS
			Design Loads	Ultimate Loads	Safety Factor	10 Passes	10,000 Passes	
ConCore CC1250-24"	Posilock	8.5 lbs / ft <sup>2</sup> 41 kg / m <sup>2</sup>	1250 lbs 567 kg	Min. 2500lbs Min. 1134kg	Min. 2	1125 lbs 510 kg	875 lbs 397 kg	150 lbs 68 kg
	Bolted Stringer	10.0 lbs / ft <sup>2</sup> 49 kg / m <sup>2</sup>	1250 lbs 567 kg	Min. 2500lbs Min. 1134kg	Min. 2	1000 lbs 454 kg	800 lbs 363 kg	150 lbs 68 kg

1. System Design Load is based on permanent set  $\leq 0.010"$  and is verified by loading panels in accordance with the CISCA concentrated load method but with panels installed on actual understructure instead of steel blocks. (Testing on blocks does not represent performance of an actual installation.) Ultimate, Rolling, and Impact Load tests are performed using CISCA test procedures.
2. Safety Factor is Ultimate Load divided by Design Load.